

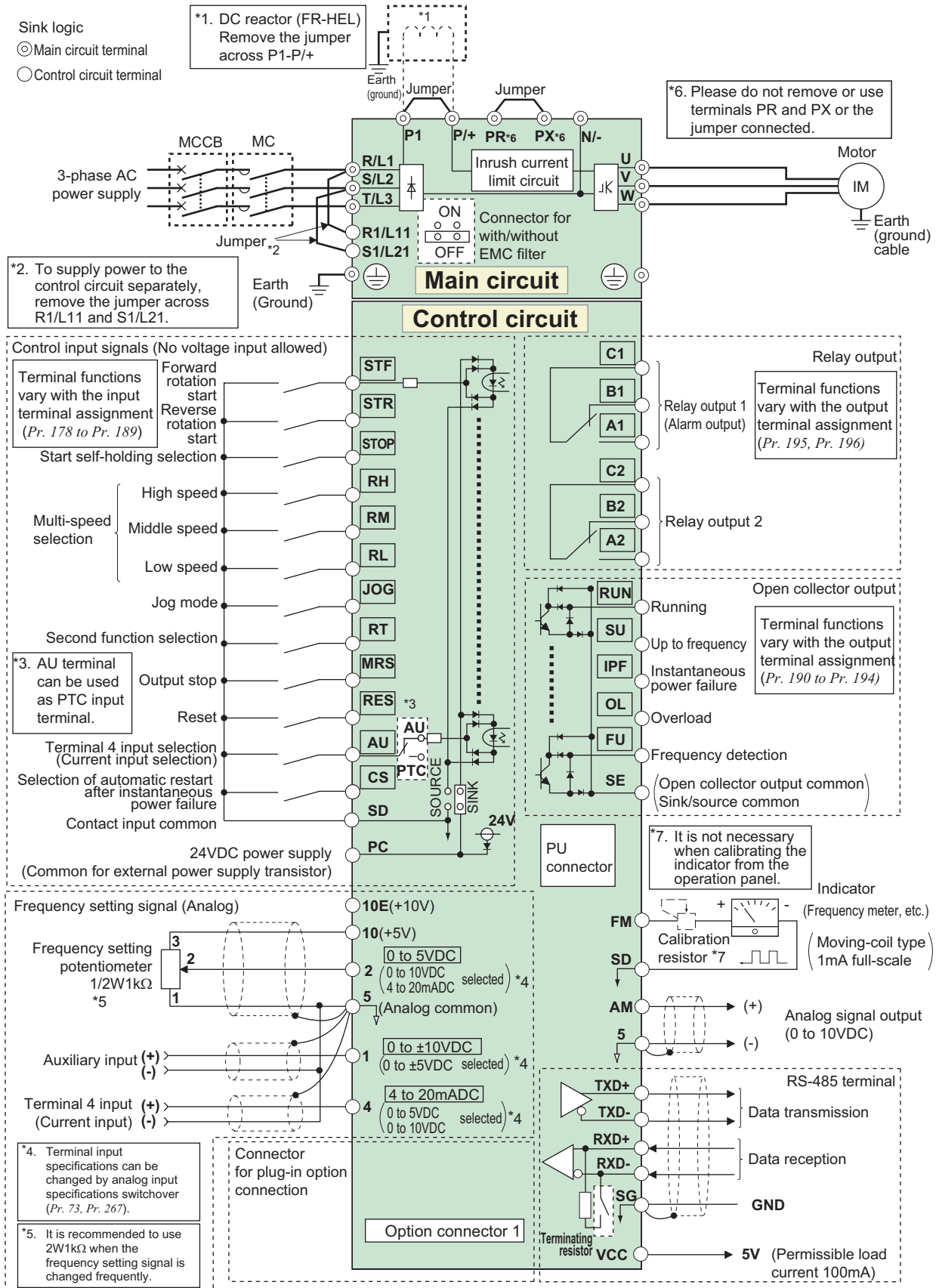

## 1.2 Wiring

### 1.2.1 Terminal connection diagram



**CAUTION**

- To prevent a malfunction due to noise, keep the signal cables more than 10cm away from the power cables.
- After wiring, wire offcuts must not be left in the inverter.  
 Wire offcuts can cause an alarm, failure or malfunction. Always keep the inverter clean.  
 When drilling mounting holes in a control box etc., take care not to allow chips and other foreign matter to enter the inverter.