

2.1 Wiring

2.1.1 Terminal connection diagram

- Three-phase 200V power input
- Three-phase 400V power input

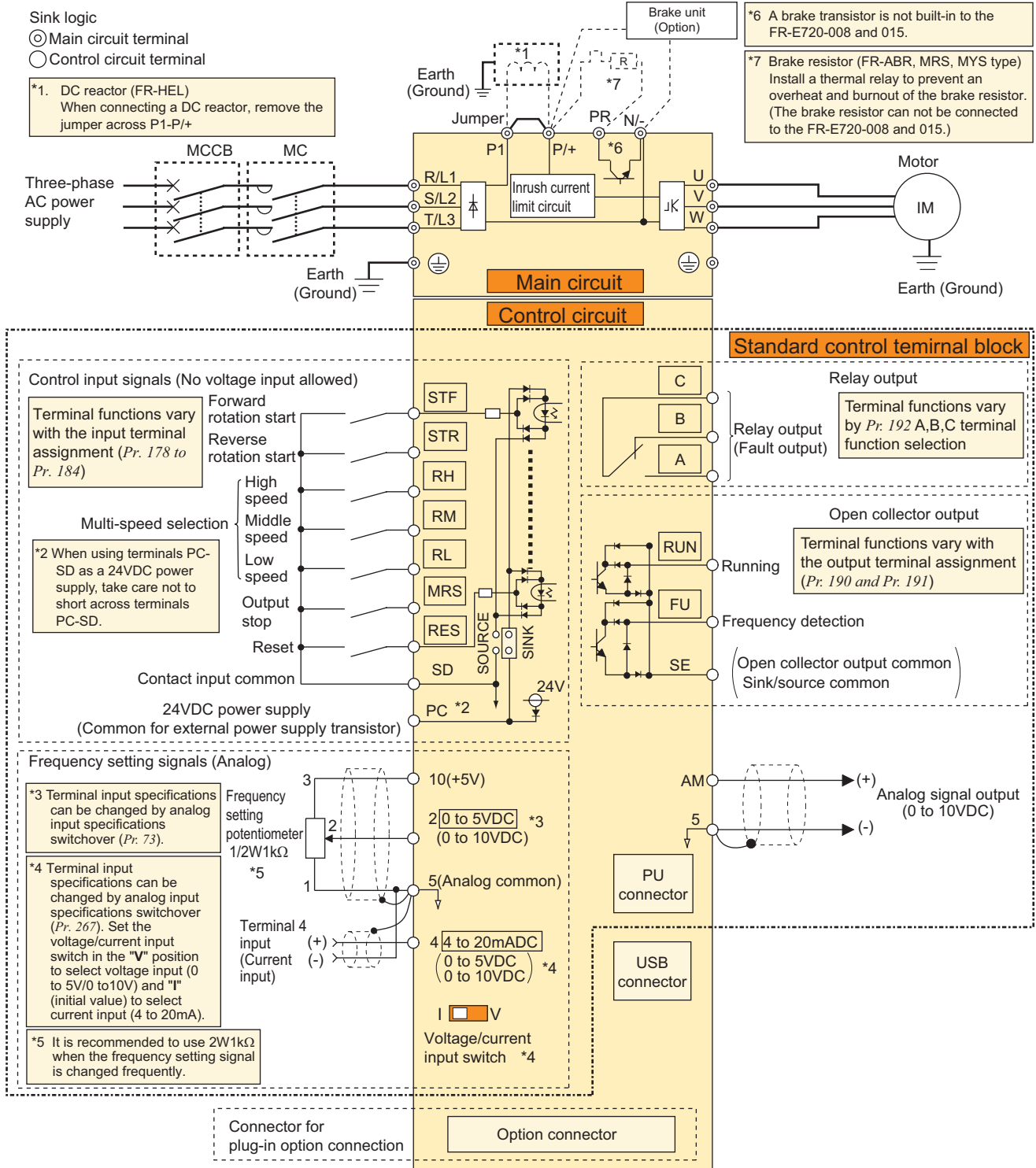

NOTE

- To prevent a malfunction caused by noise, separate the signal cables more than 10cm (3.94inches) from the power cables.
- After wiring, wire offcuts must not be left in the inverter. Wire offcuts can cause an alarm, failure or malfunction. Always keep the inverter clean. When drilling mounting holes in an enclosure etc., take care not to allow chips and other foreign matter to enter the inverter.

2.2 Main circuit terminal specifications

2.2.1 Specification of main circuit terminal

Terminal Symbol	Terminal Name	Description
R/L1, S/L2, T/L3	AC power input	Connect to the commercial power supply. Keep these terminals open when using the high power factor converter (FR-HC) or power regeneration common converter (FR-CV).
U, V, W	Inverter output	Connect a three-phase squirrel-cage motor.
P/+, PR	Brake resistor connection	Connect a brake transistor (FR-ABR, MRS, MYS) across terminals P/+ -PR. (The brake resistor can not be connected to the FR-E720-008 or 015.)
P/+, N/-	Brake unit connection	Connect the brake unit (FR-BU2), power regeneration common converter (FR-CV) or high power factor converter (FR-HC).
P/+, P1	DC reactor connection	Remove the jumper across terminals P/+ -P1 and connect a DC reactor.
	Earth (Ground)	For earthing (grounding) the inverter chassis. Must be earthed (grounded).

2.2.2 Terminal arrangement of the main circuit terminal, power supply and the motor wiring

200V class

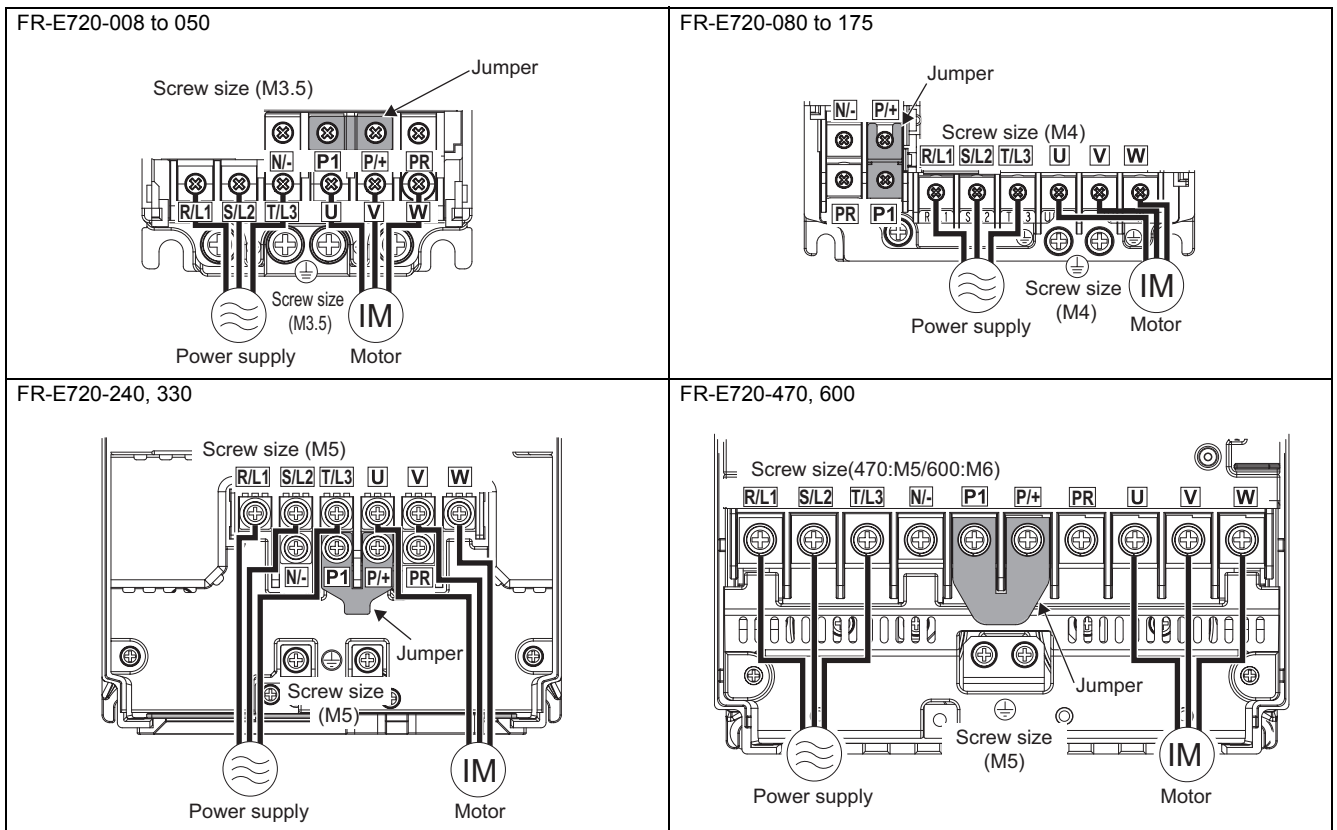

7 Main circuit terminal specifications

400V class

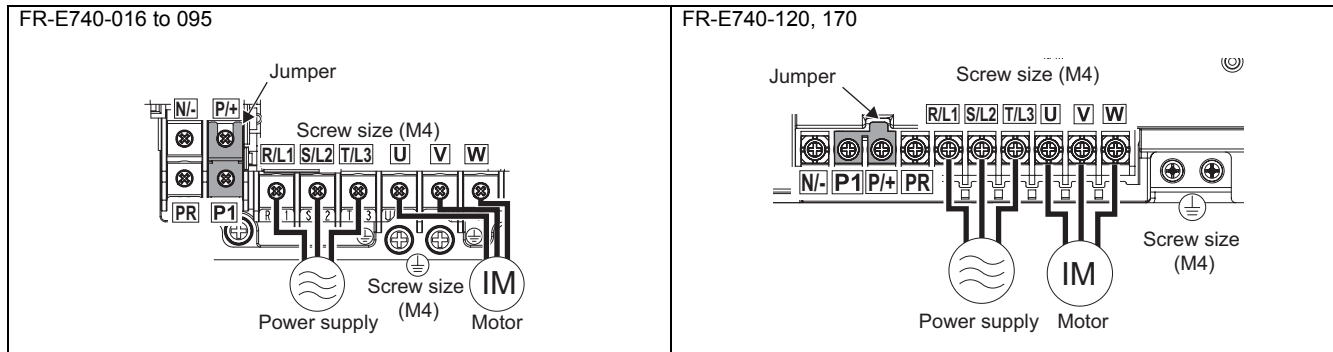

NOTE

- Make sure the power cables are connected to the R/L1, S/L2, T/L3. Never connect the power cable to the U, V, W of the inverter. Doing so will damage the inverter. (Phase need not be matched.)
- Connect the motor to U, V, W. Turning on the forward rotation switch (signal) at this time rotates the motor counterclockwise when viewed from the load shaft.