

2.1 Wiring

2.1.1 Terminal connection diagram

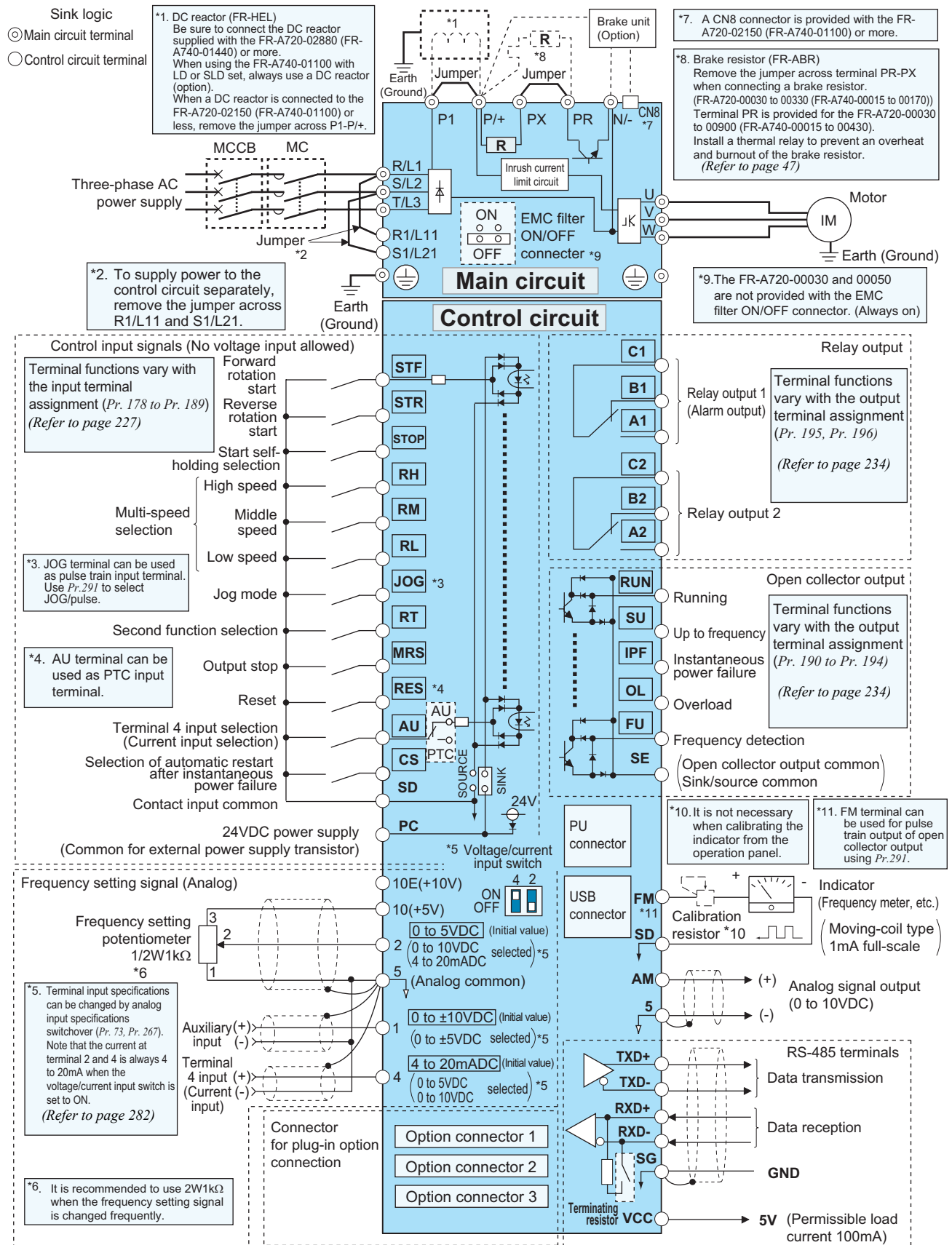

CAUTION

- To prevent a malfunction due to noise, keep the signal cables more than 10cm (3.94inches) away from the power cables.
- After wiring, wire cutoffs must not be left in the inverter.
- Wire cutoffs can cause an alarm, failure or malfunction. Always keep the inverter clean.
- When drilling mounting holes in an enclosure etc., take care not to allow chips and other foreign matter to enter the inverter.